

Data-Intensive Distributed Computing

CS 451/651 (Fall 2018)

Part 2: From MapReduce to Spark (2/2)

September 25, 2018

Jimmy Lin

David R. Cheriton School of Computer Science

University of Waterloo

These slides are available at <http://lintool.github.io/bigdata-2018f/>



This work is licensed under a Creative Commons Attribution-NonCommercial-Share Alike 3.0 United States
See <http://creativecommons.org/licenses/by-nc-sa/3.0/us/> for details



An Apt Quote

All problems in computer science can be solved by another level of indirection... Except for the problem of too many layers of indirection.

- David Wheeler

An aerial photograph of a large industrial datacenter facility during sunset. The sun is a bright orange orb in the upper left corner, casting a warm glow over the scene. The facility consists of several large, white, rectangular buildings with flat roofs, arranged in a grid-like pattern. A prominent feature is a large, open-air area with rows of white cylindrical tanks or containers. The surrounding landscape is a mix of green fields and brown, tilled earth. In the background, there are more buildings and a road. The overall atmosphere is serene and industrial.

The datacenter *is* the computer!

What's the instruction set?
What are the abstractions?

MapReduce

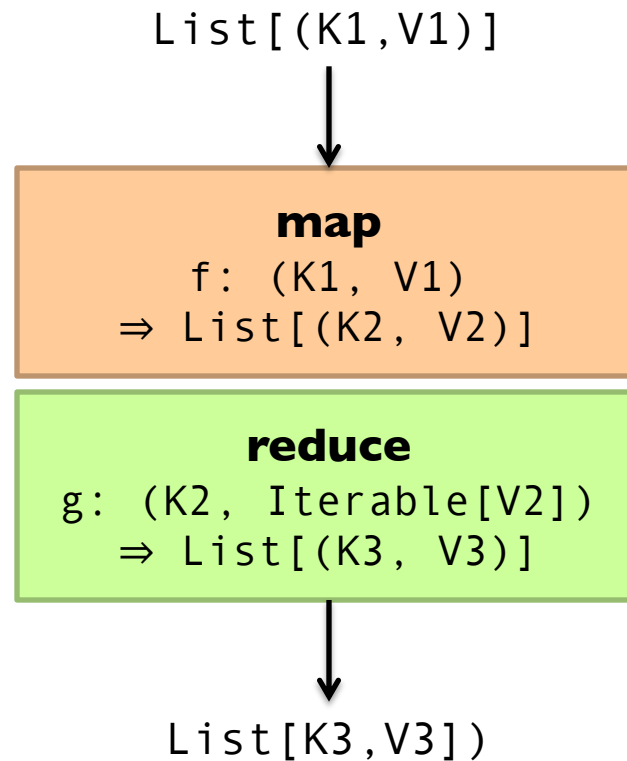

Spark

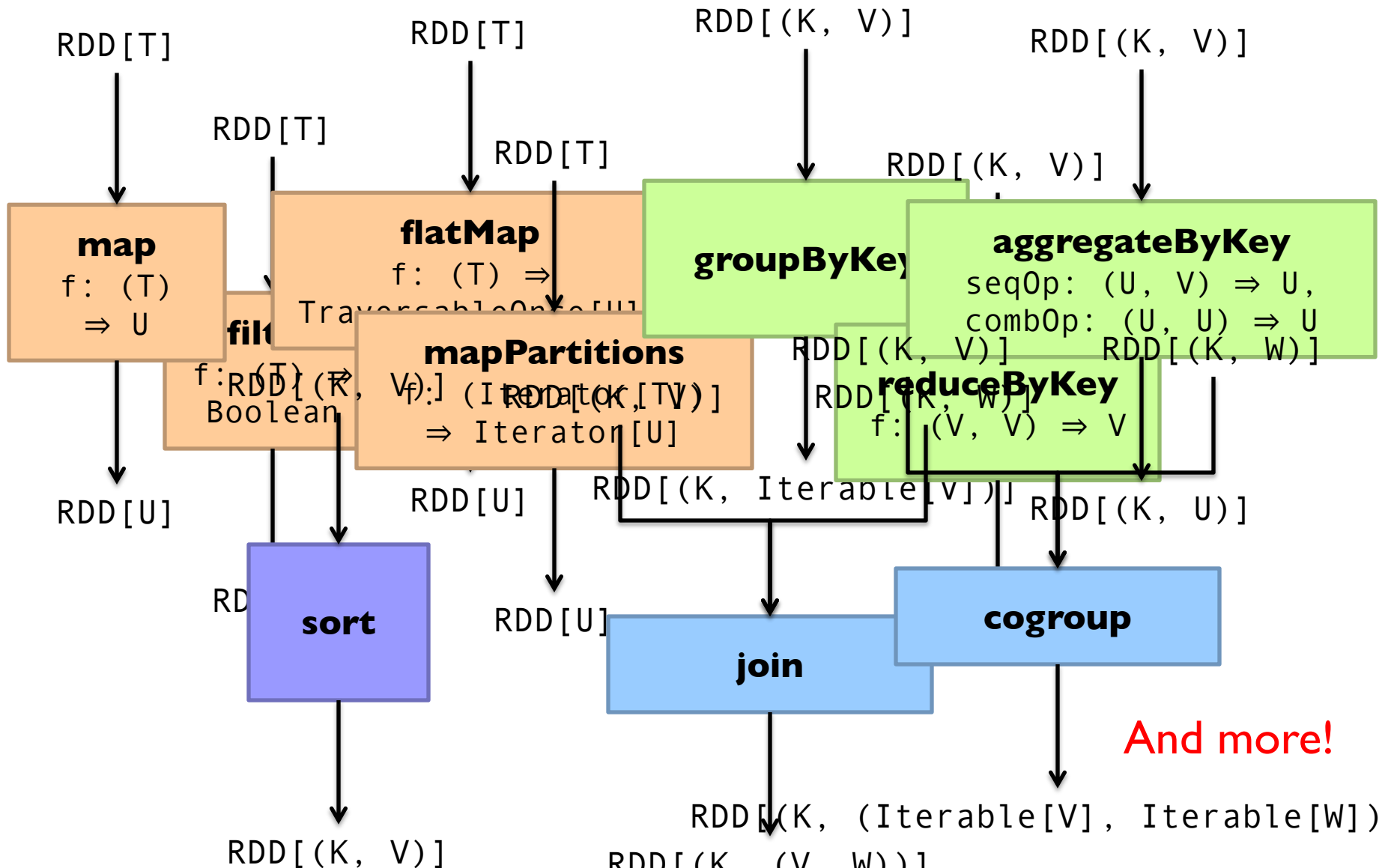

Spark Word Count

```
val textFile = sc.textFile(args.input())
```

```
textFile
```

```
  .flatMap(line => tokenize(line))  
  .map(word => (word, 1))  
  .reduceByKey((x, y) => x + y)  
  .saveAsTextFile(args.output())
```

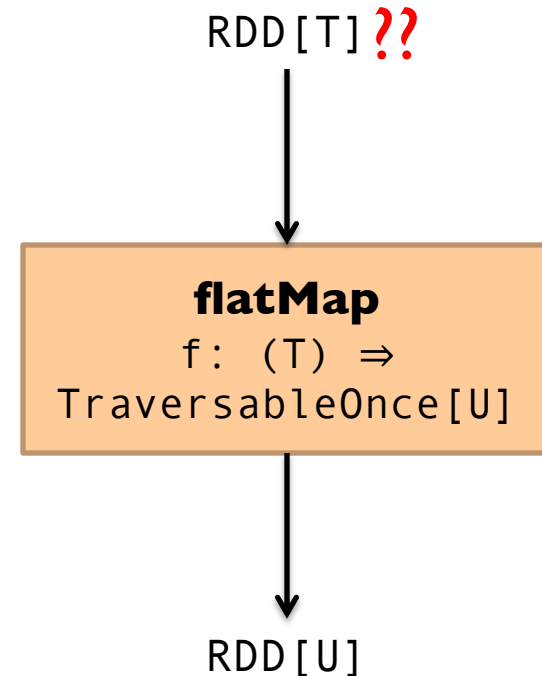

What's an RDD?

Resilient Distributed Dataset (RDD)

= immutable = partitioned

Wait, so how do you actually do anything?

Developers define *transformations* on RDDs

Framework keeps track of lineage

RDD Lifecycle

Transformation

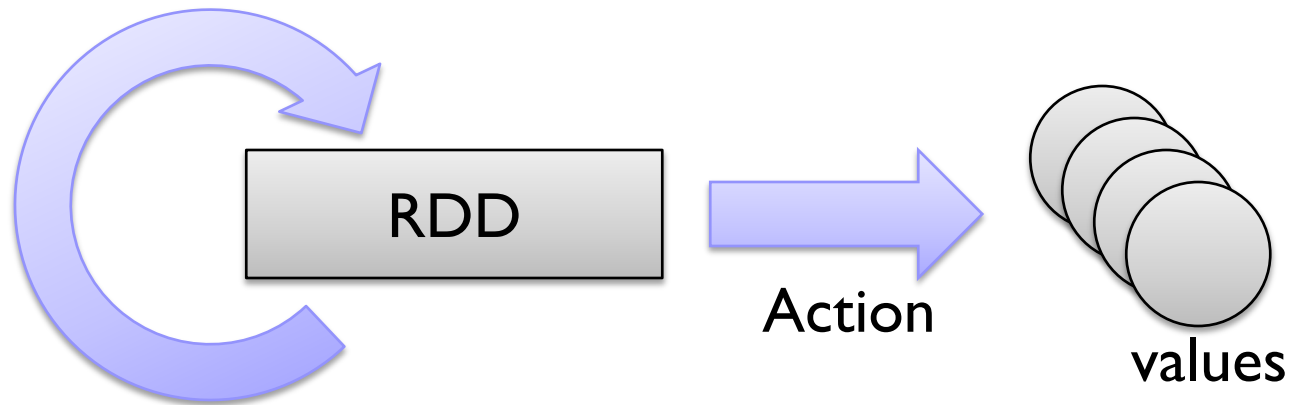

Transformations are lazy:
Framework keeps track of lineage

Actions trigger actual execution

Spark Word Count

RDDs

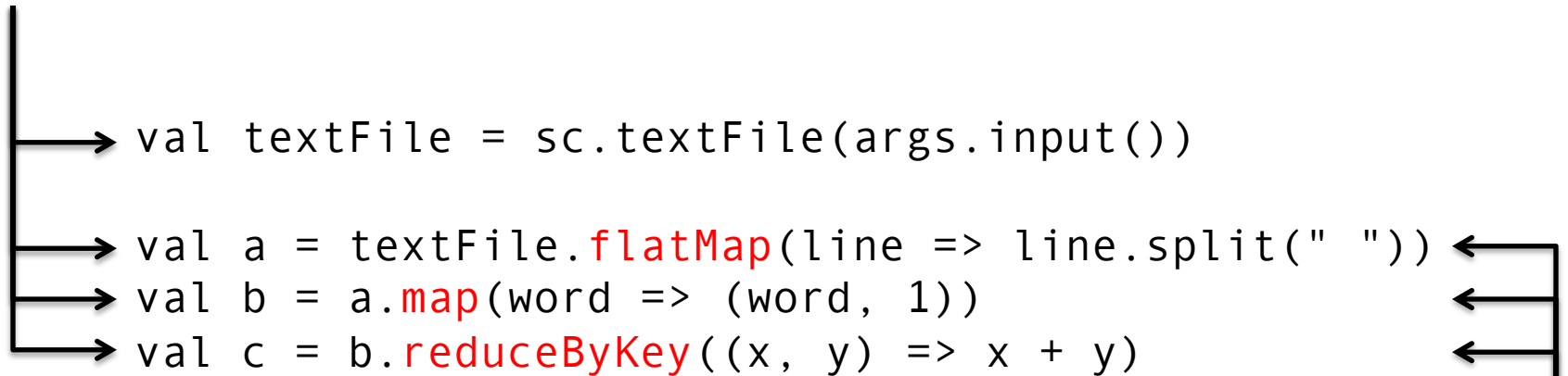

`c.saveAsTextFile(args.output())`

Action
↑

Transformations

RDDs and Lineage

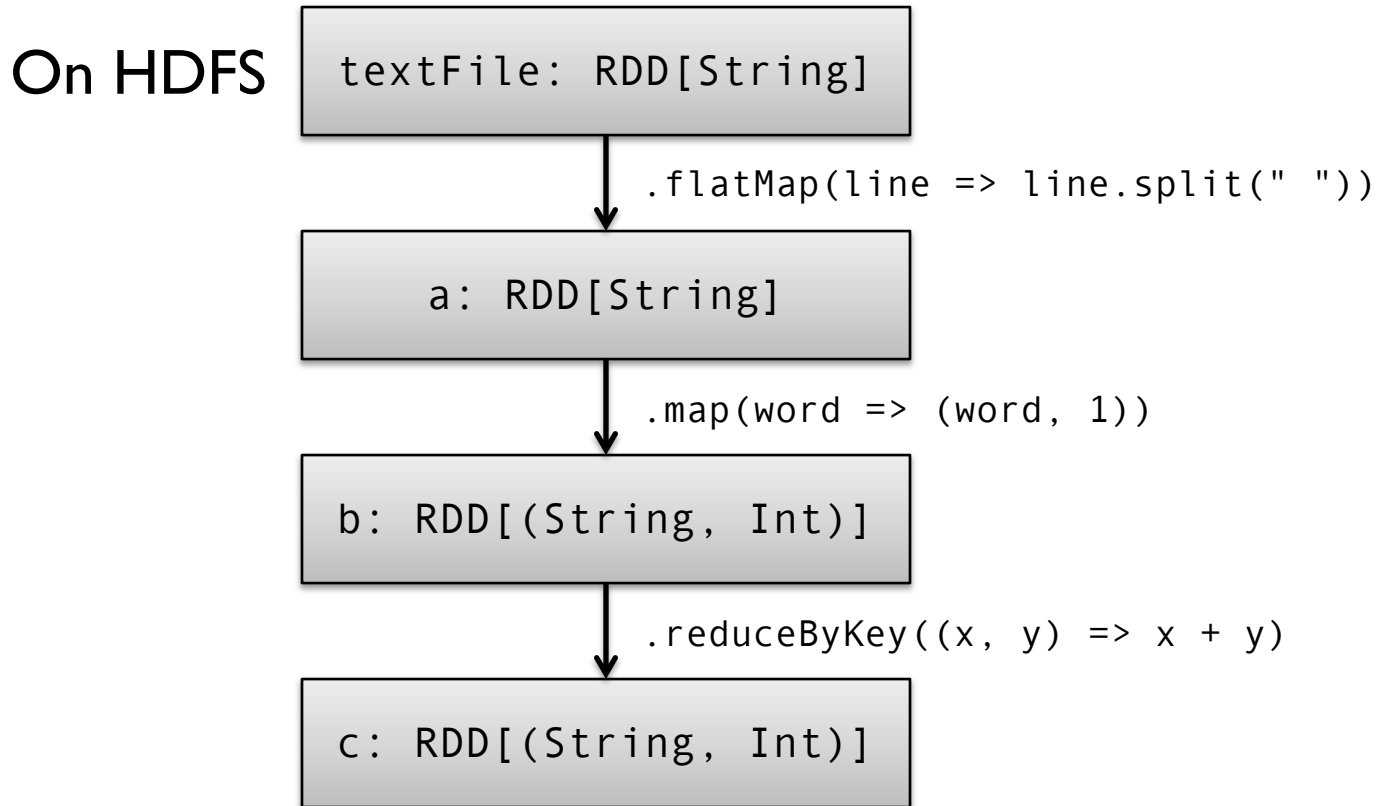

Action!

**Remember,
transformations are lazy!**

RDDs and Optimizations

Lazy evaluation creates optimization opportunities

On HDFS

textFile: RDD[String]

RDDs don't need
to be materialized!

Want MM?

.flatMap(line => line.split(" "))

a: RDD[String]

.map(word => (word, 1))

b: RDD[(String, Int)]

.reduceByKey((x, y) => x + y)

c: RDD[(String, Int)]

Action!

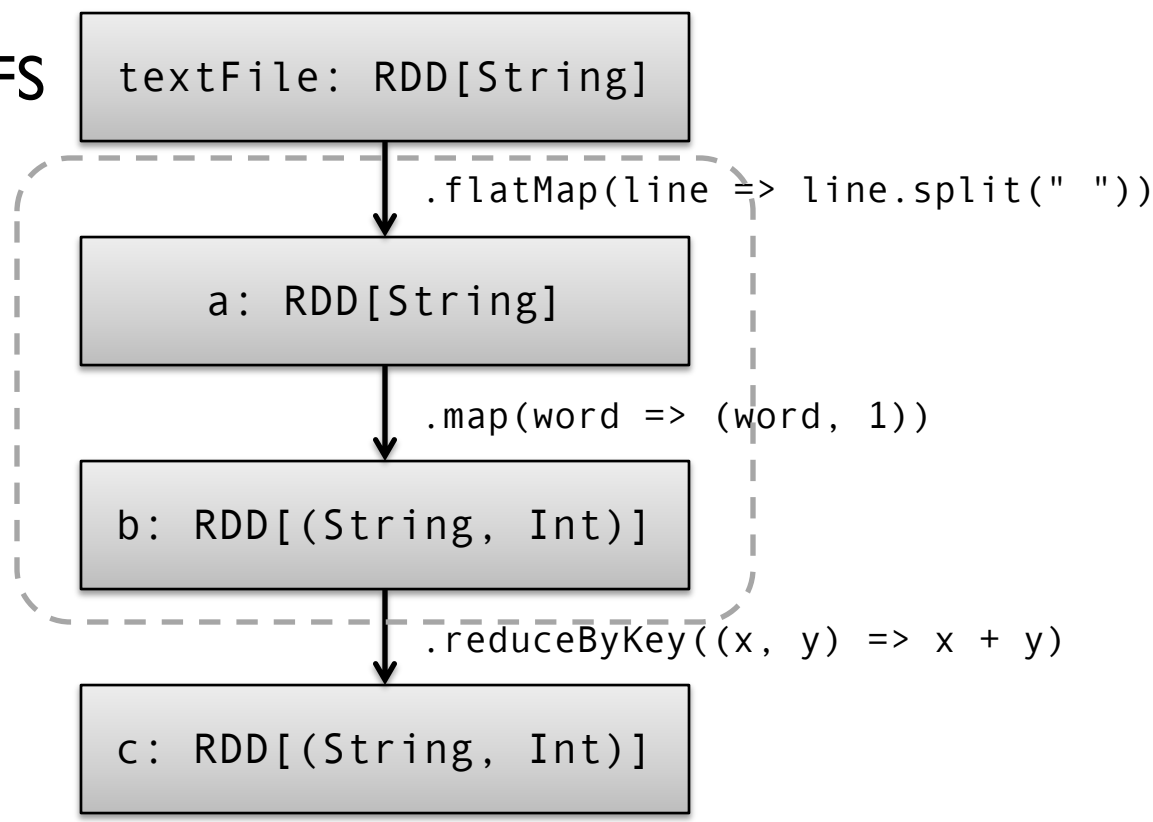

RDDs and Caching

RDDs can be materialized in memory (and on disk)!

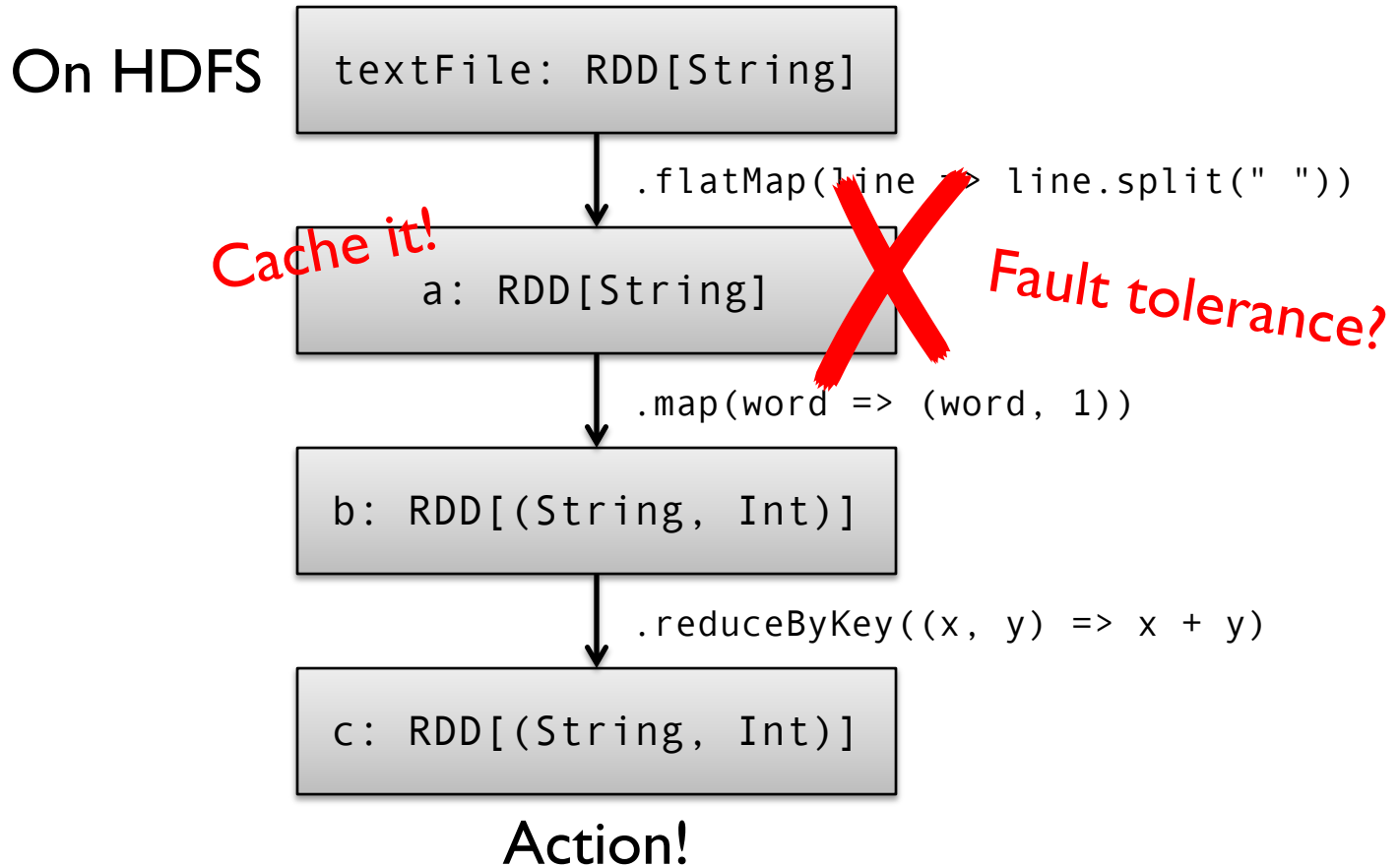

Spark works even if the RDDs are *partially* cached!

Spark Architecture

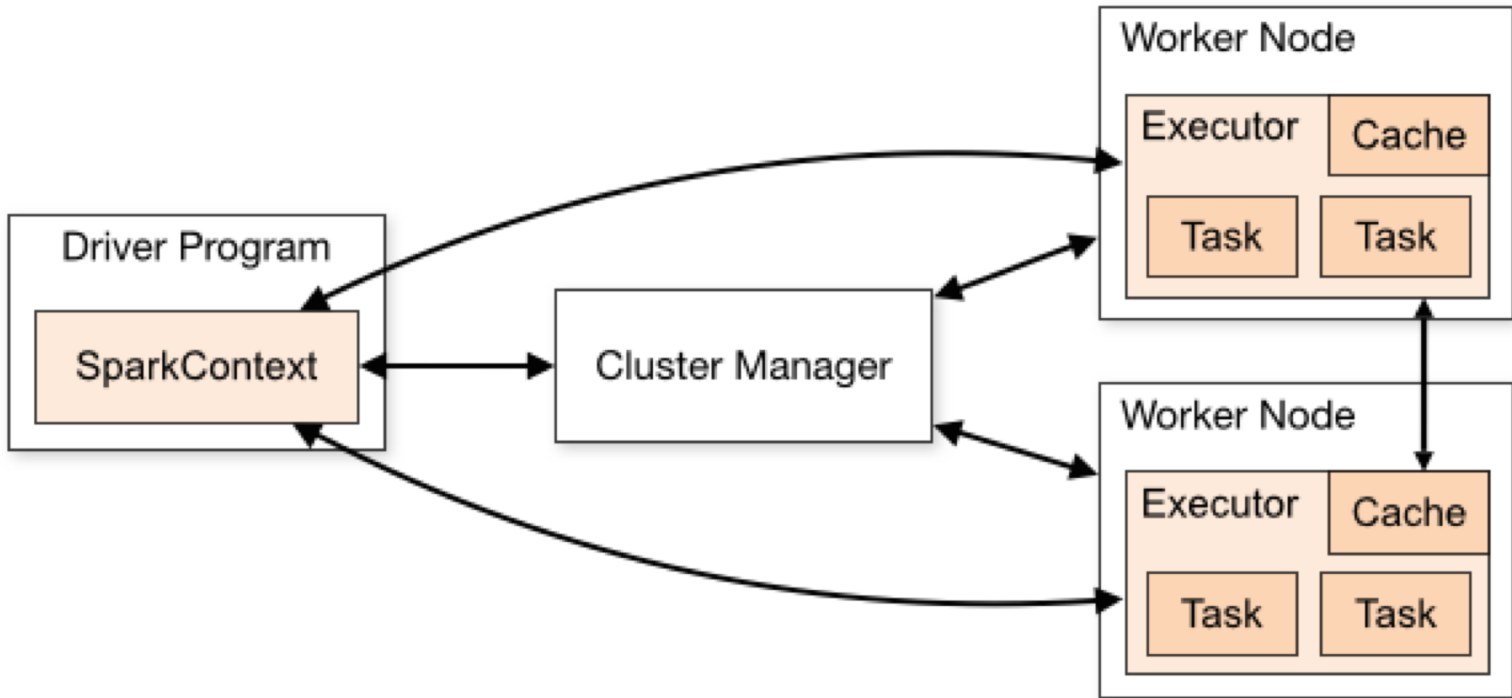

Hadoop MapReduce Architecture

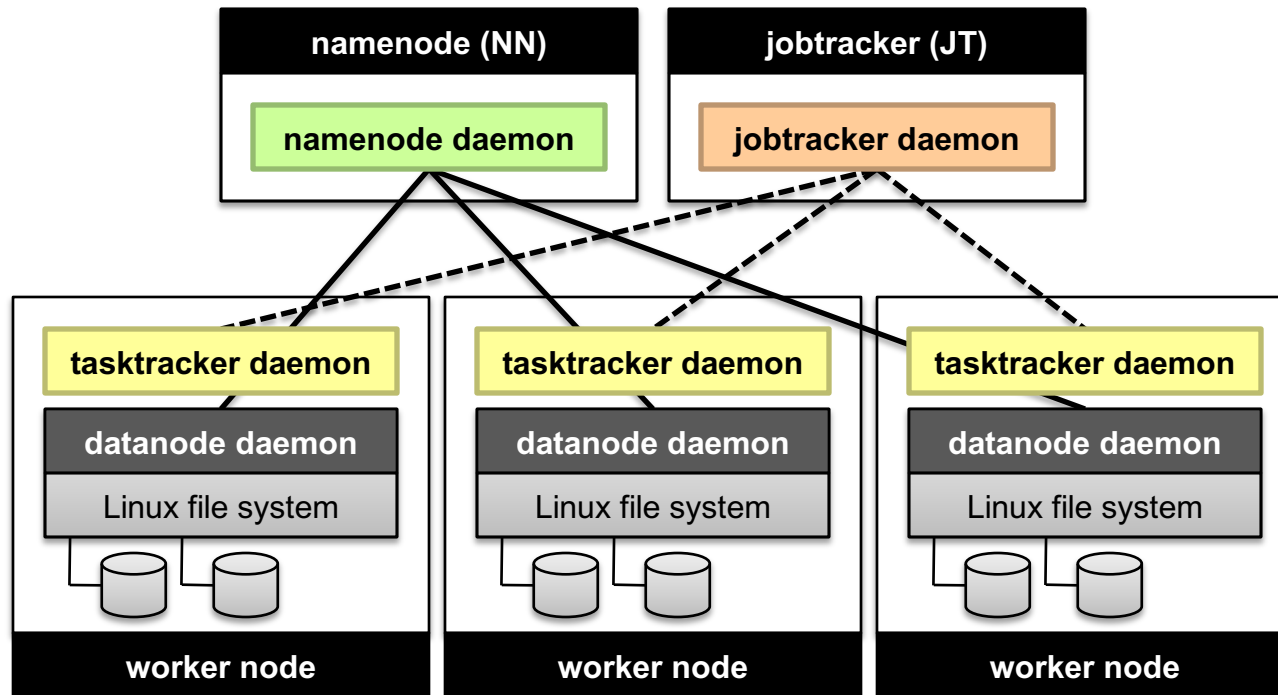

An Apt Quote

All problems in computer science can be solved by another level of indirection... Except for the problem of too many layers of indirection.

- David Wheeler

YARN

Hadoop's (original) limitations:

Can only run MapReduce

What if we want to run other distributed frameworks?

YARN = Yet-Another-Resource-Negotiator

Provides API to develop any generic distributed application

Handles scheduling and resource request

MapReduce (MR2) is one such application in YARN

YARN

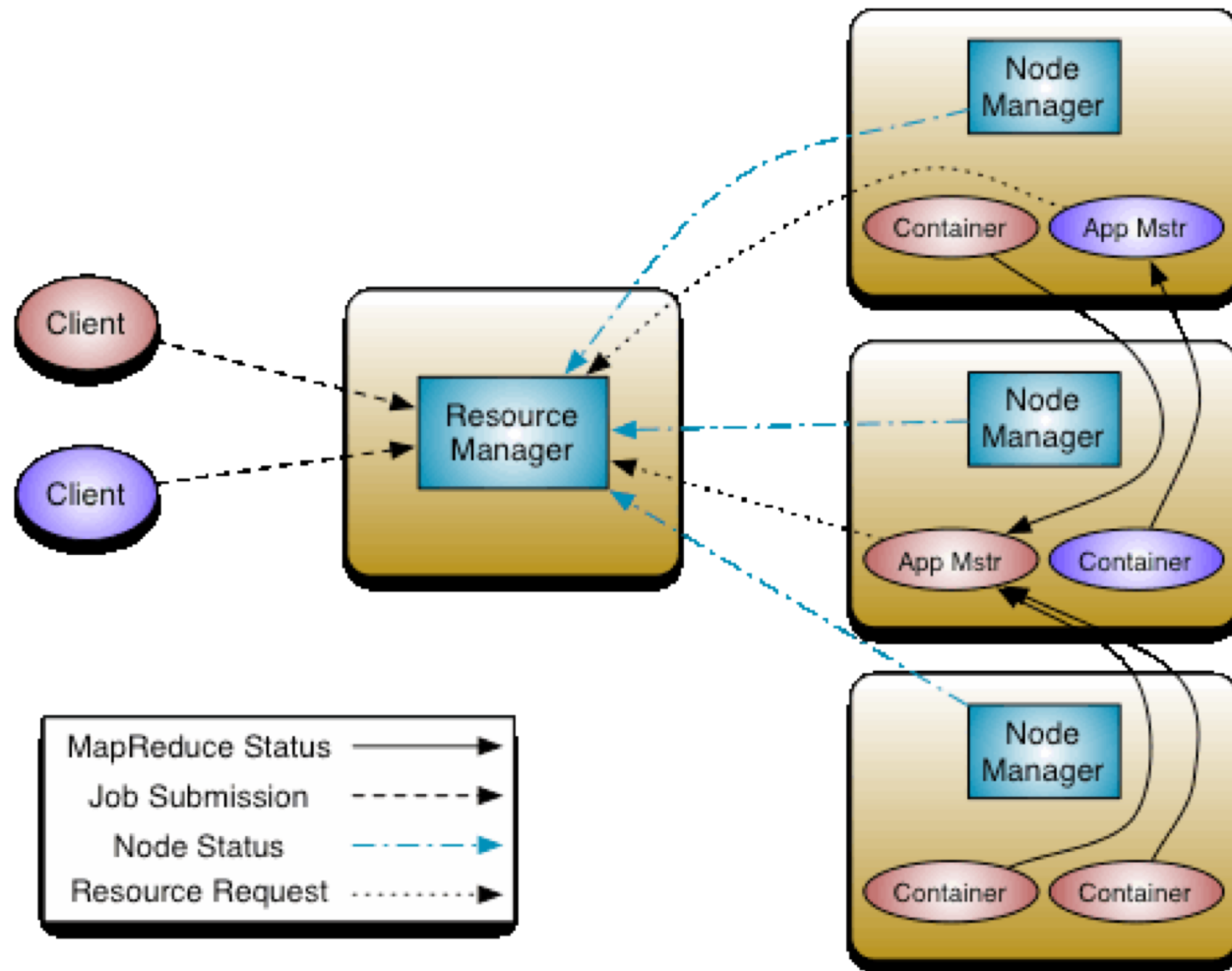

Spark Programs

Scala, Java, Python, R

spark-shell spark-submit

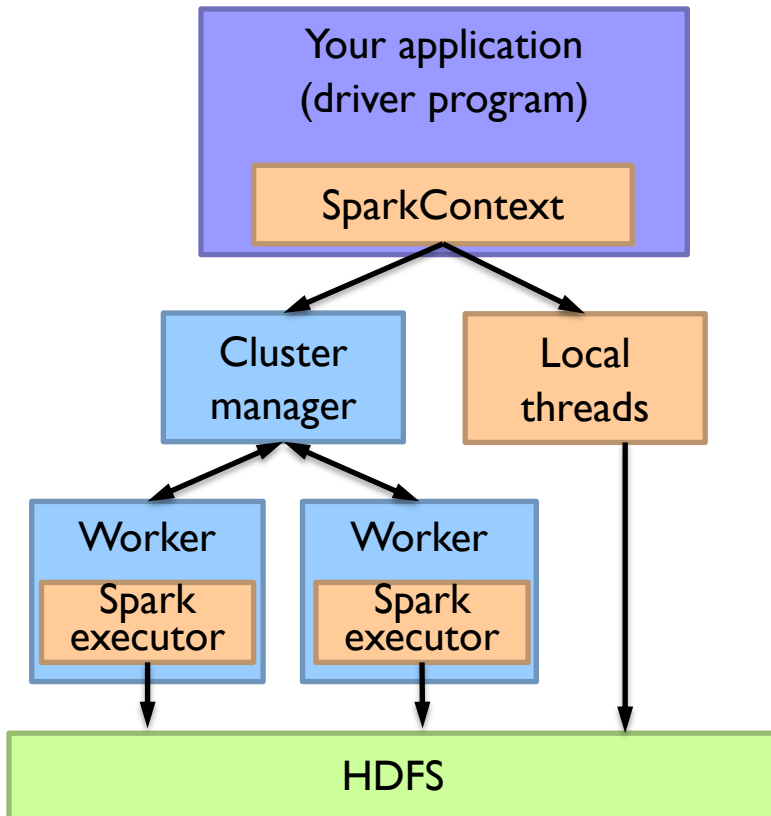

Spark context: tells the framework where to find the cluster

Use the Spark context to create RDDs

Spark Driver

spark-shell spark-submit

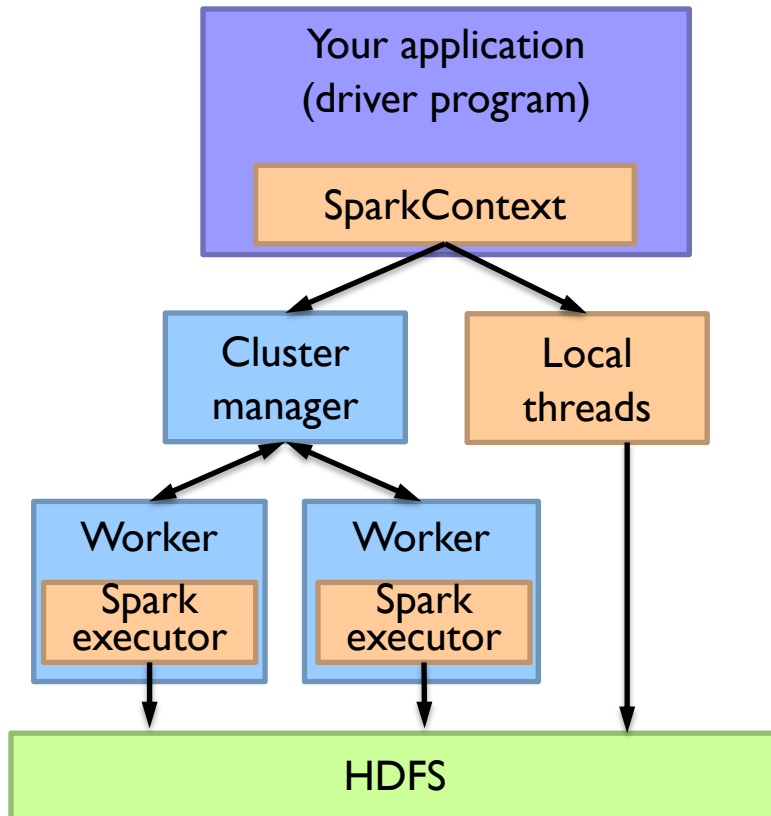

```
val textFile =  
  sc.textFile(args.input())
```

```
textFile  
  .flatMap(line => tokenize(line))  
  .map(word => (word, 1))  
  .reduceByKey((x, y) => x + y)  
  .saveAsTextFile(args.output())
```

What's happening
to the functions?

Spark Driver

spark-shell spark-submit

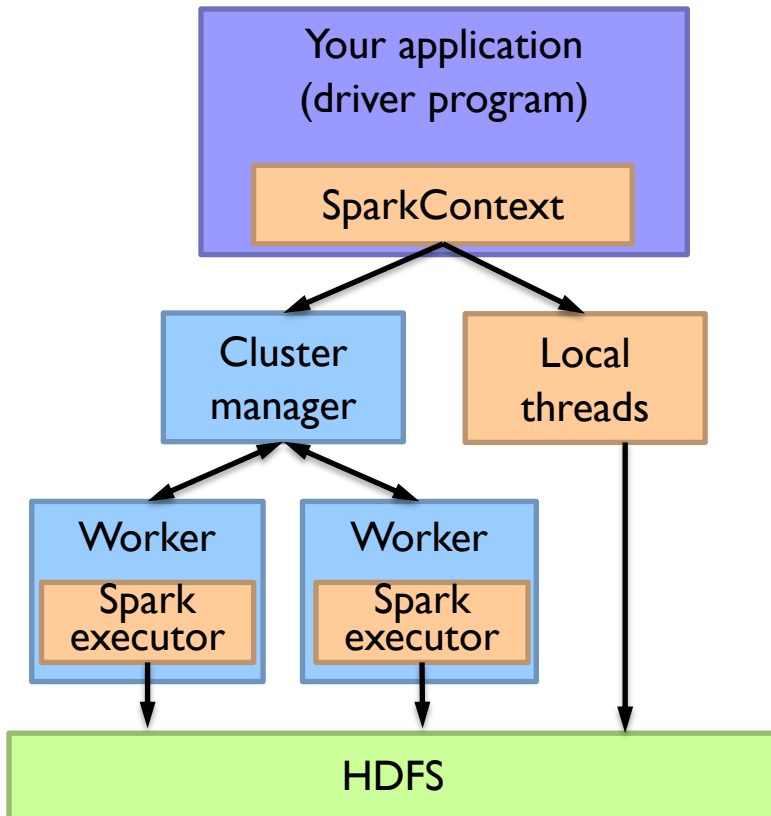

```
val textFile =  
  sc.textFile(args.input())
```

```
textFile  
  .flatMap(line => tokenize(line))  
  .map(word => (word, 1))  
  .reduceByKey((x, y) => x + y)  
  .saveAsTextFile(args.output())
```

Note: you can run code “locally”,
integrate cluster-computed values!

Beware of the collect action!

Spark Transformations

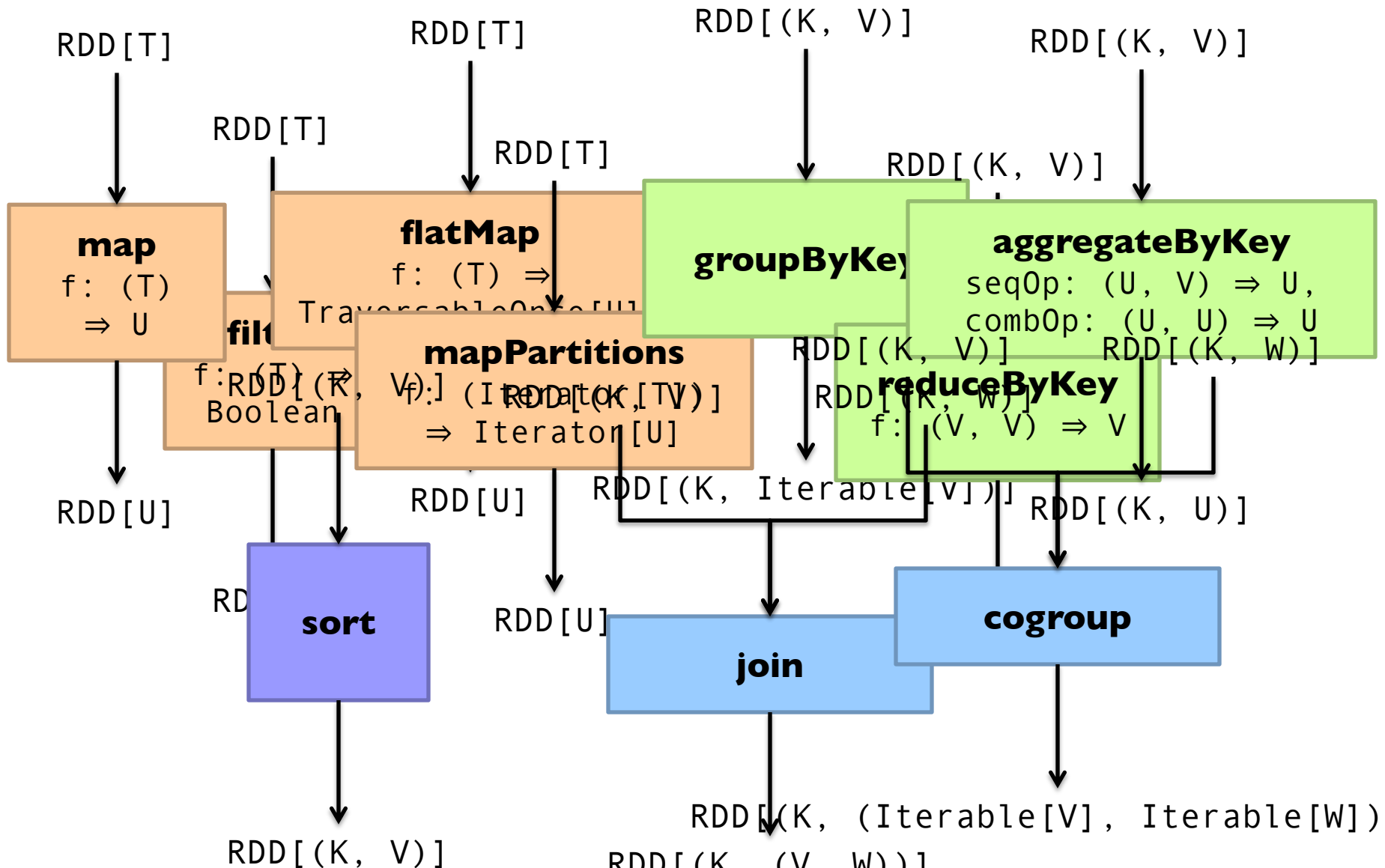

Starting Points

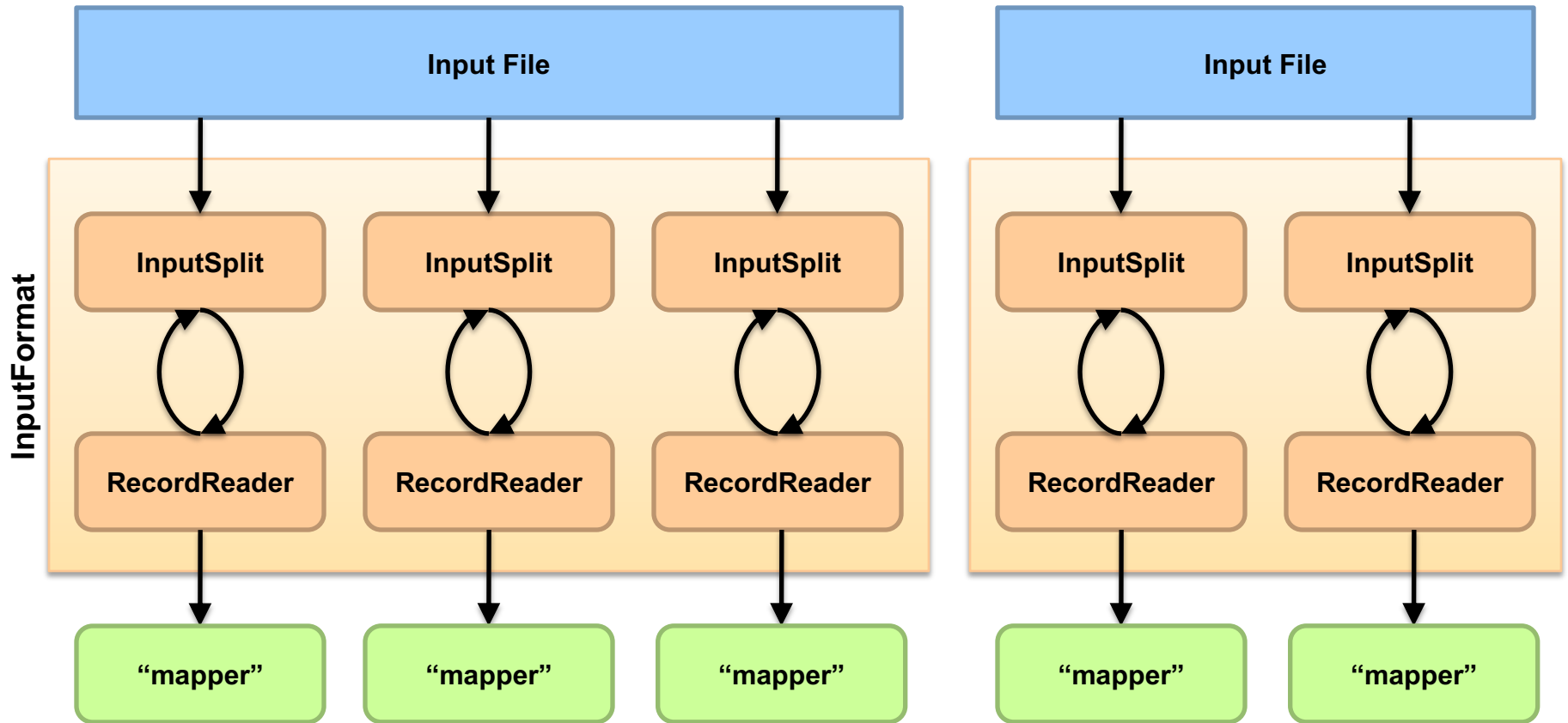

Physical Operators

Narrow Dependencies:

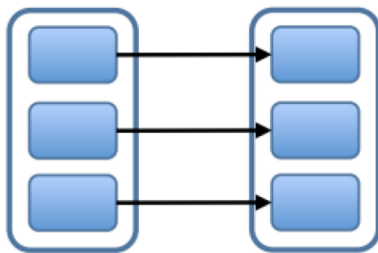

map, filter

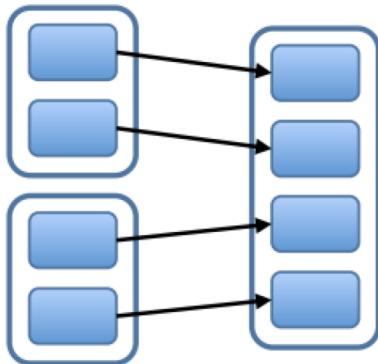

union

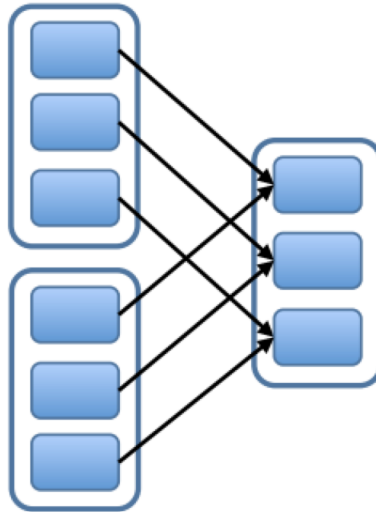

join with inputs
co-partitioned

Wide Dependencies:

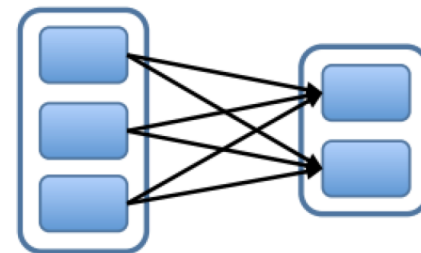

groupByKey

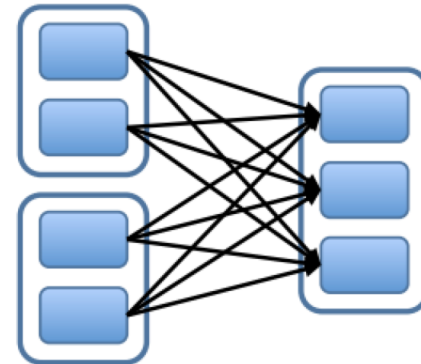

join with inputs not
co-partitioned

Execution Plan

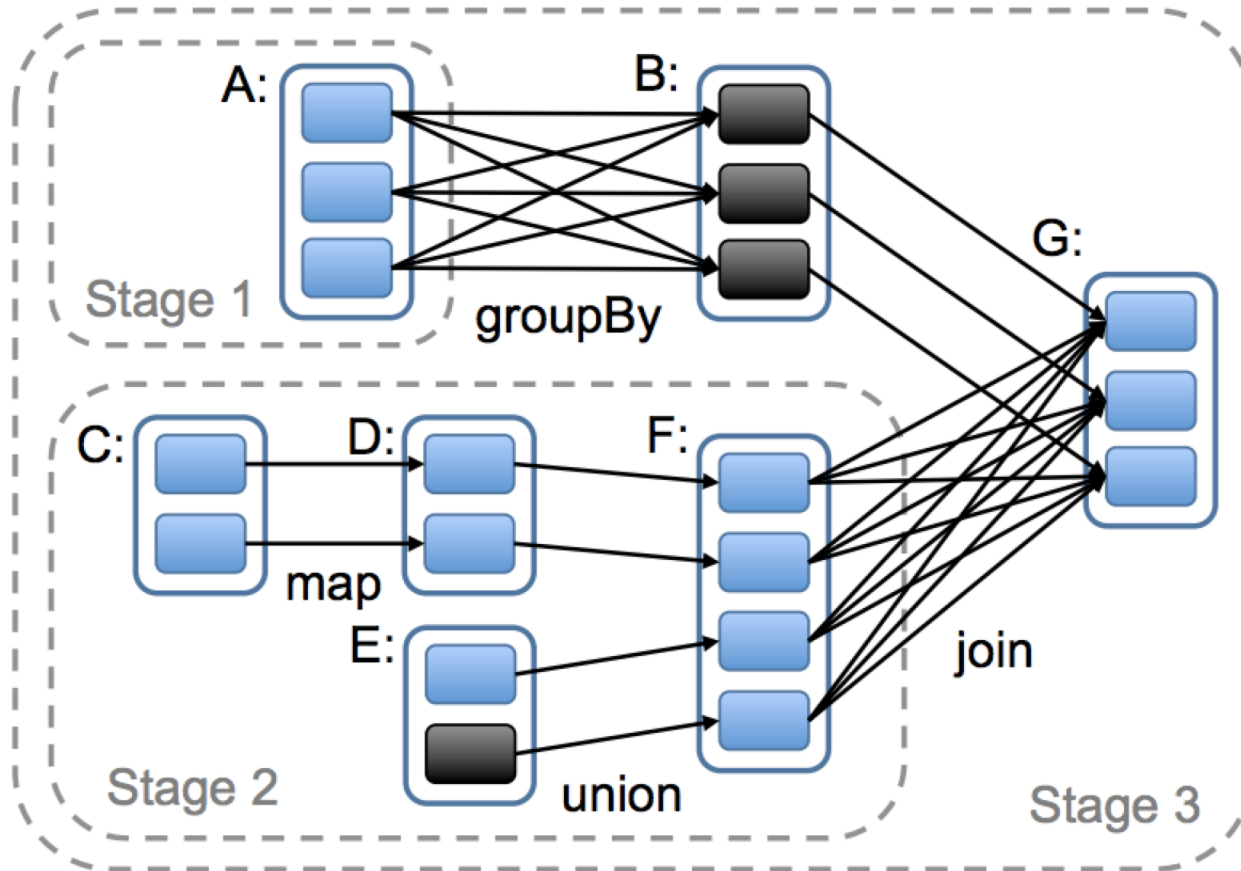

Wait, where have we seen this before?

Pig: Example Script

```
visits = load '/data/visits' as (user, url, time);
gVisits = group visits by url;
visitCounts = foreach gVisits generate url, count(visits);
urlInfo = load '/data/urlInfo' as (url, category, pRank);
visitCounts = join visitCounts by url, urlInfo by url;
gCategories = group visitCounts by category;
topUrls = foreach gCategories generate top(visitCounts,10);

store topUrls into '/data/topUrls';
```

Pig Query Plan

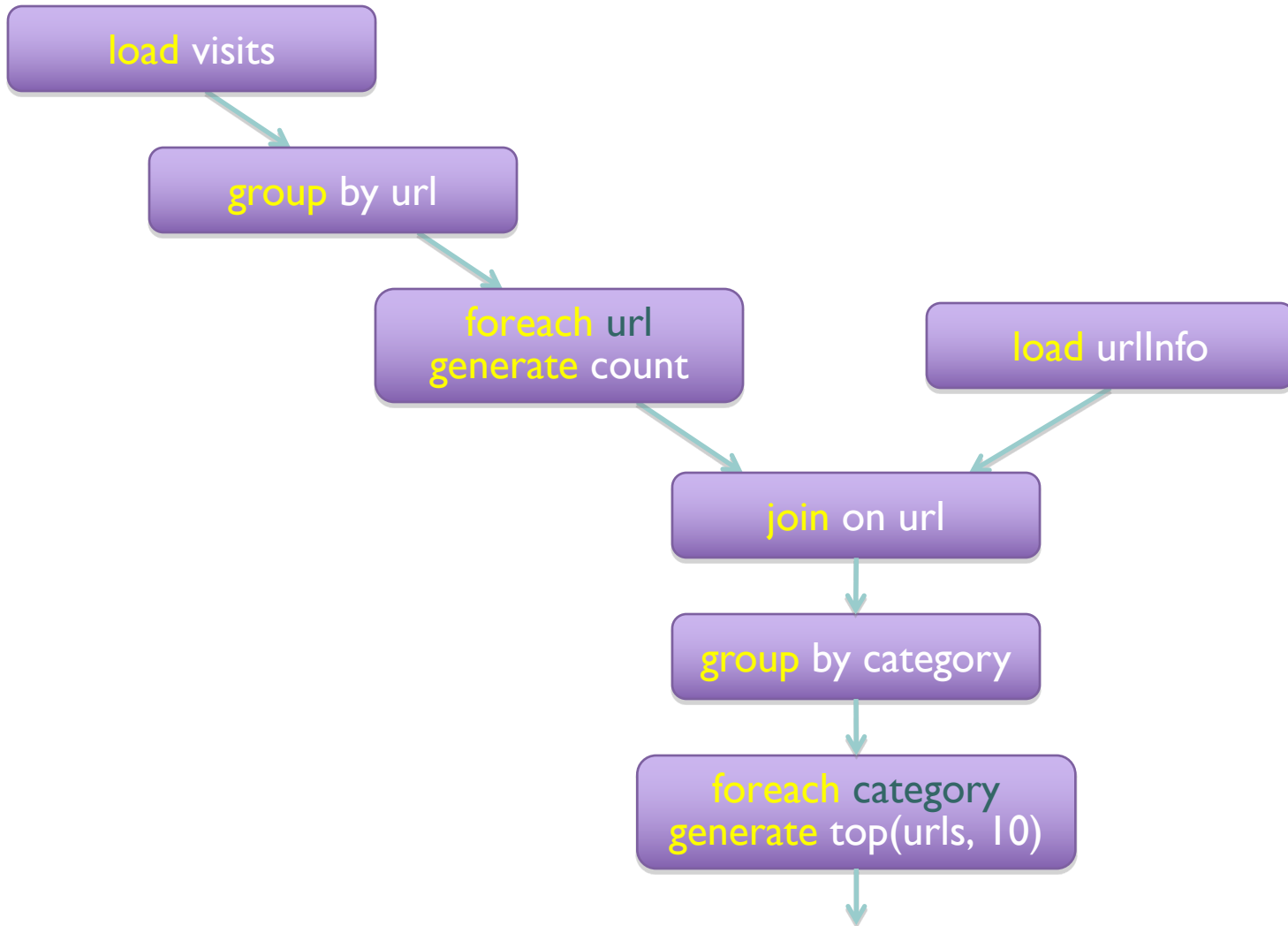

Pig: MapReduce Execution

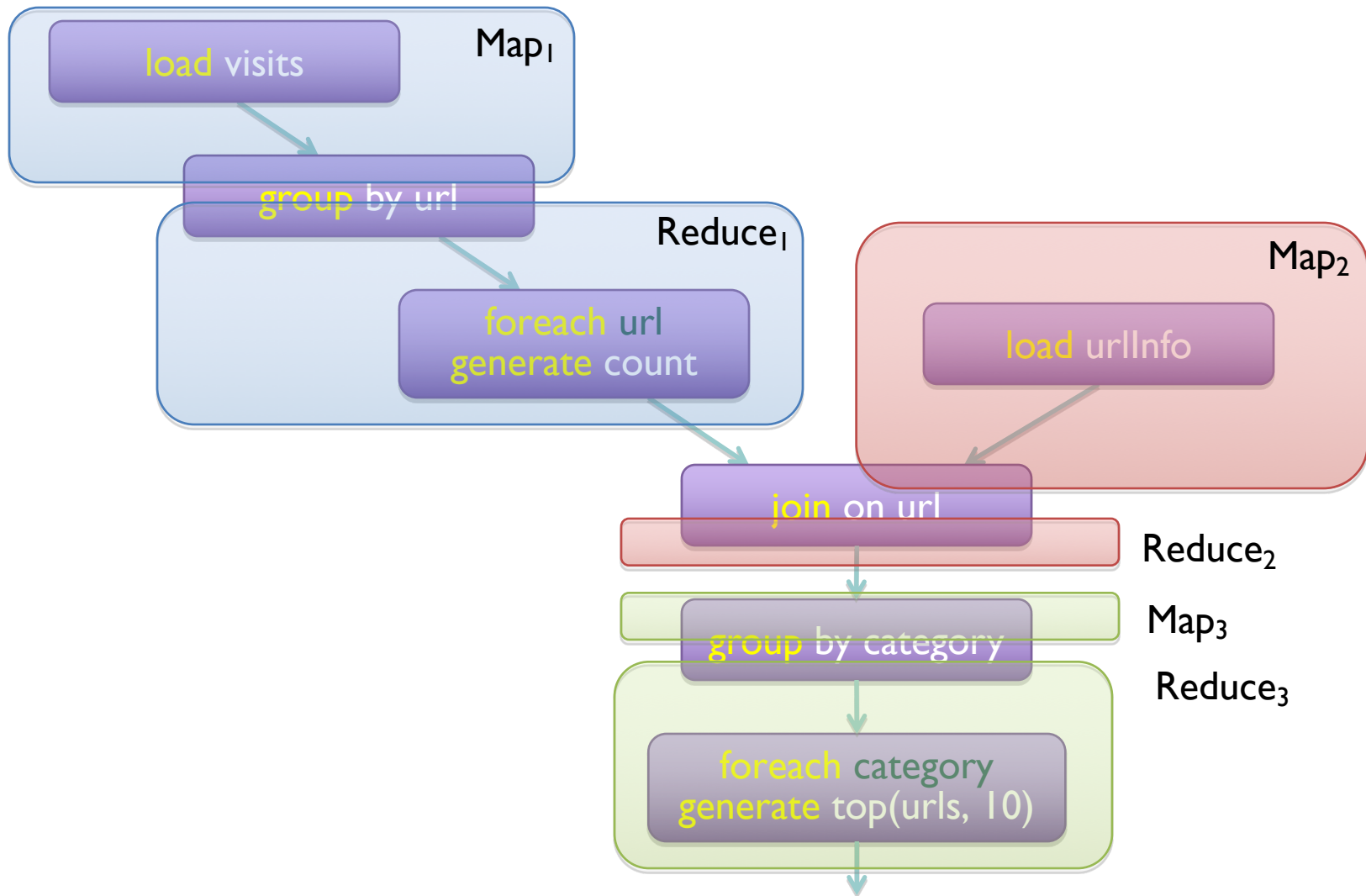

Execution Plan

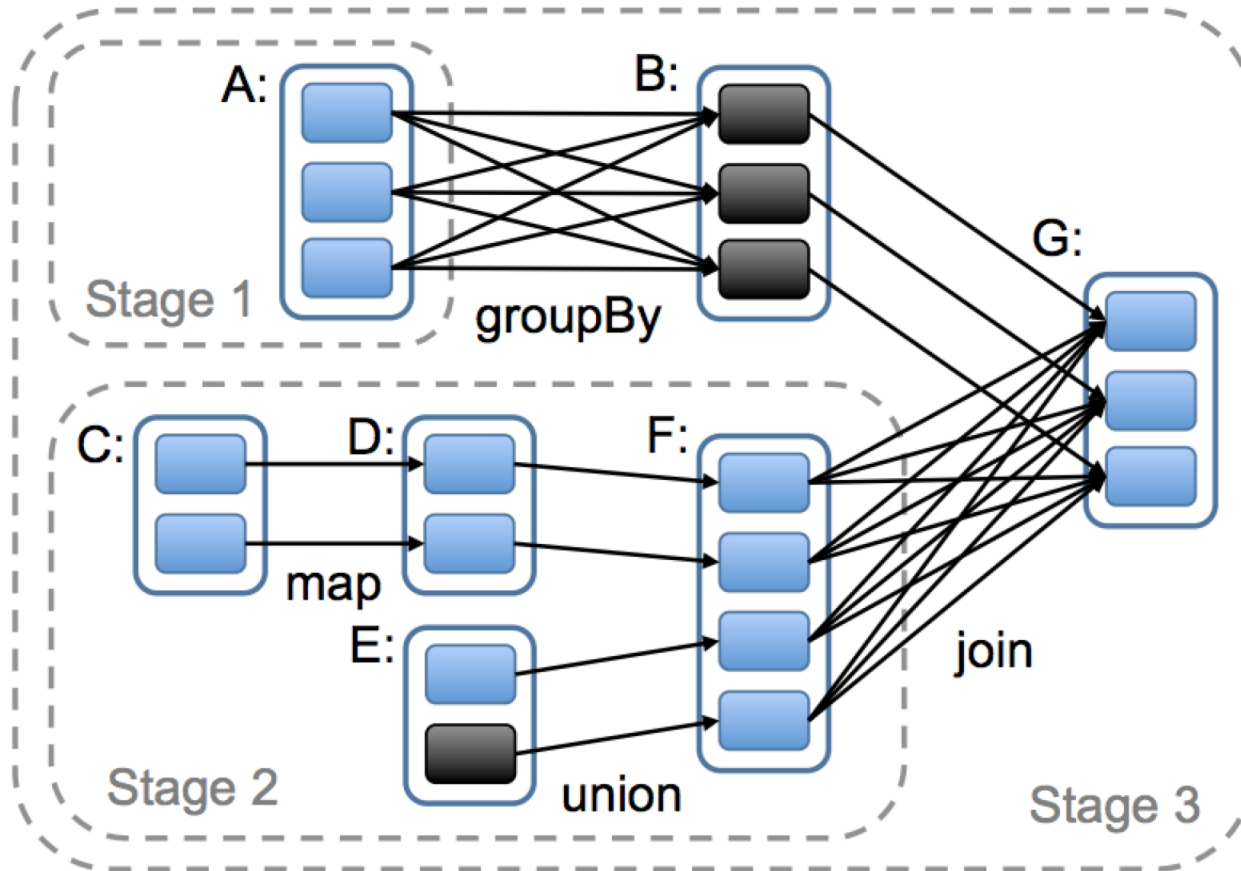

Kinda like a sequence of MapReduce jobs?

Can't avoid this!

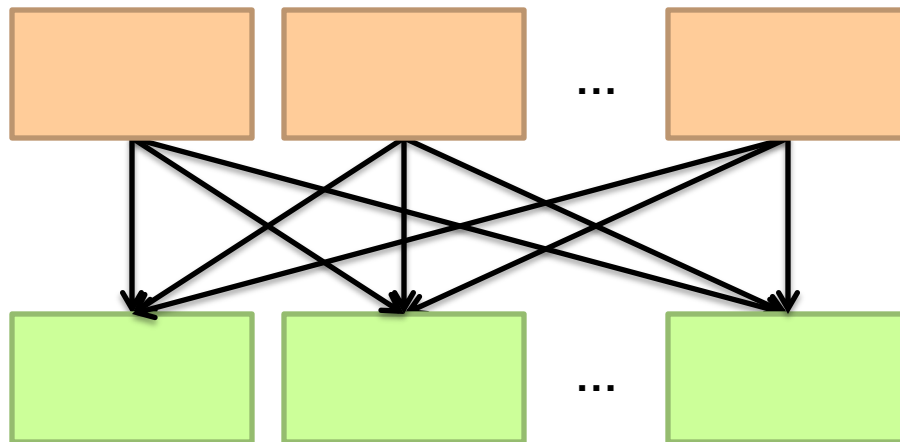

But, what's the major difference?

Remember this?

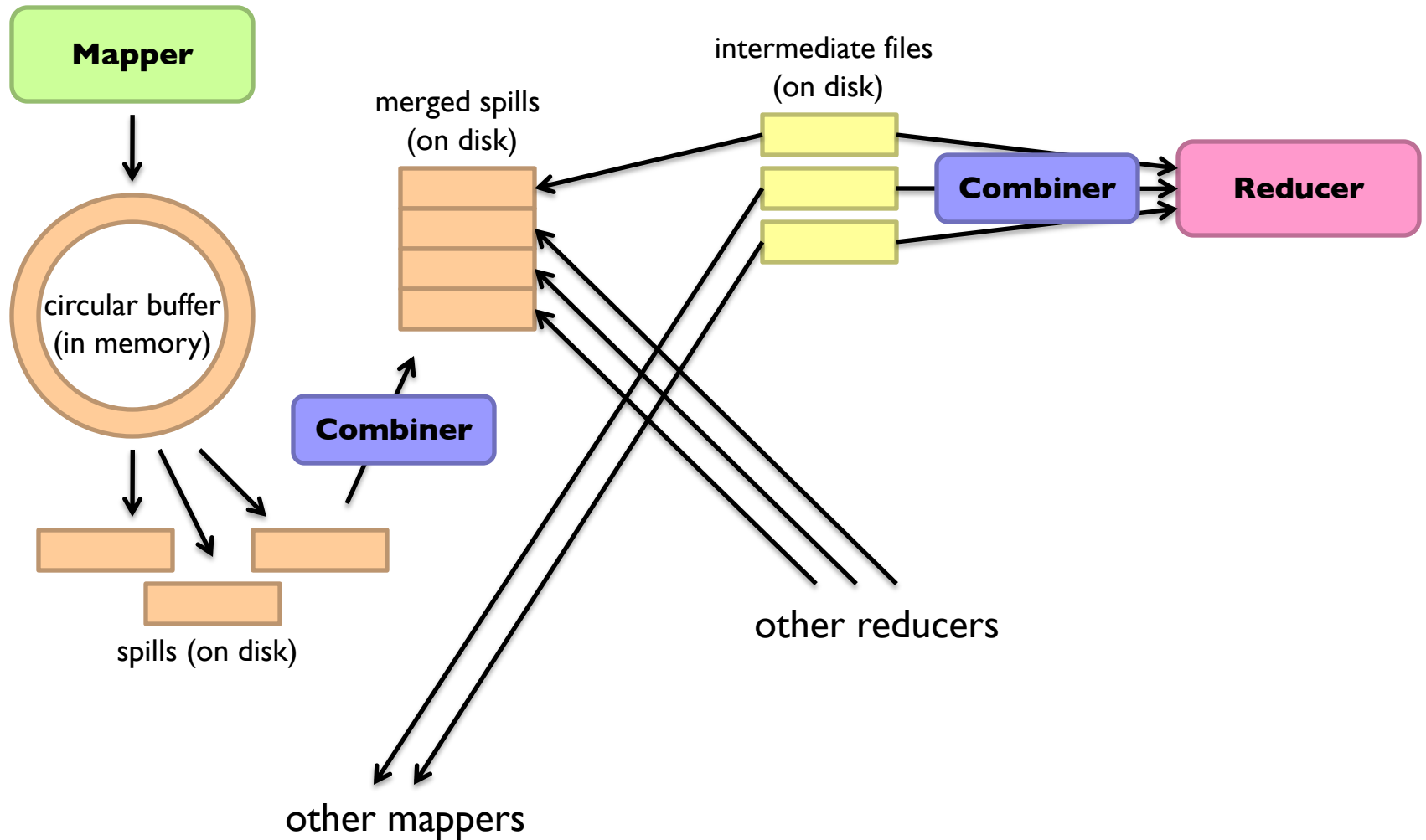

Spark Shuffle Implementations

Hash shuffle

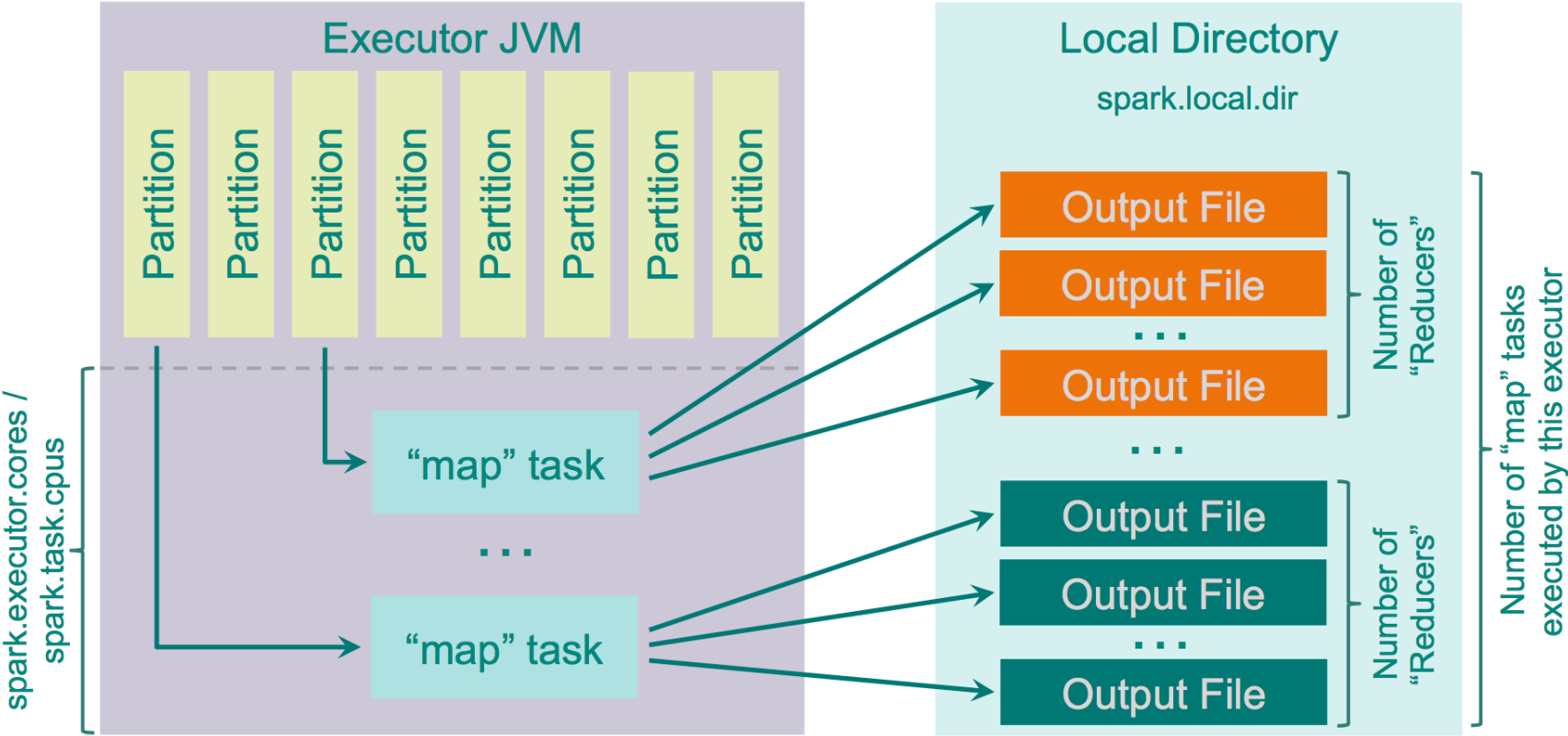

What happened to sorting?

Spark Shuffle Implementations

Sort shuffle

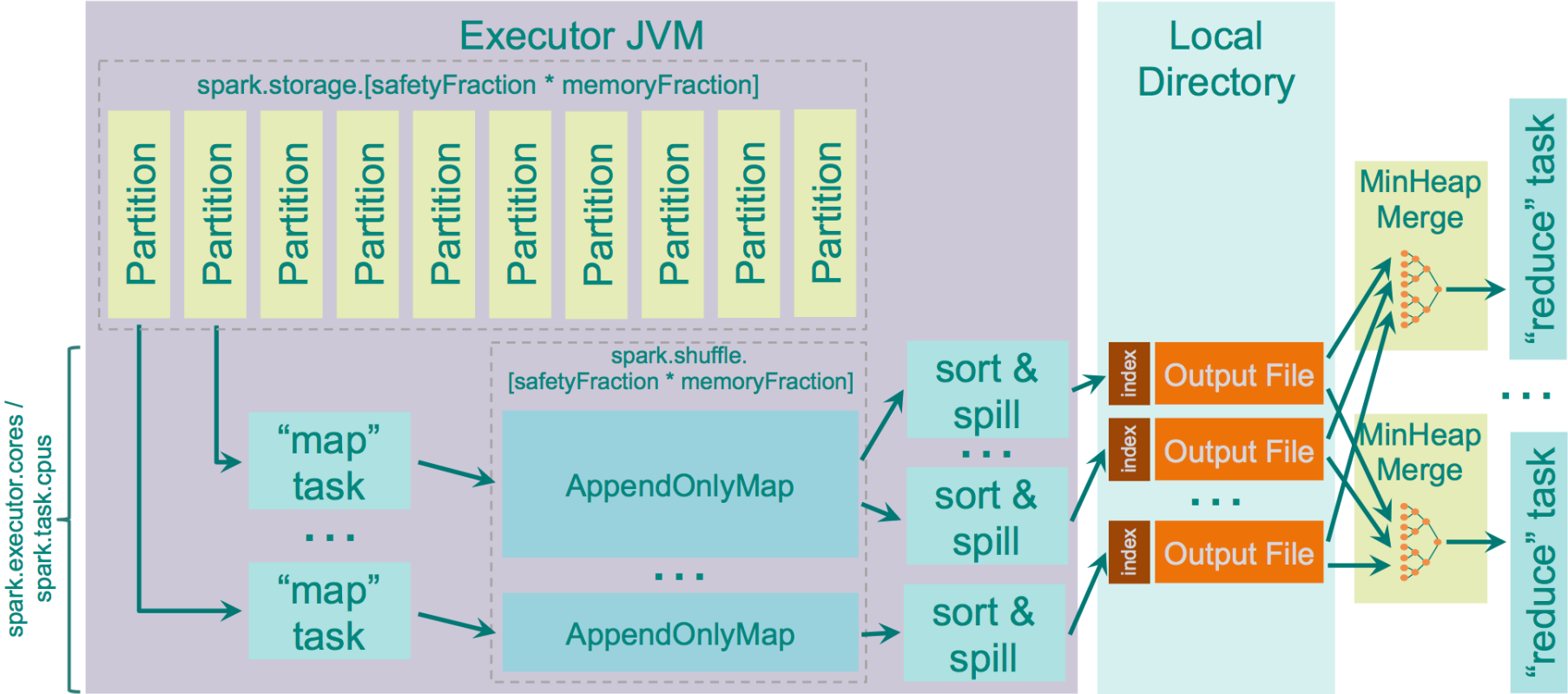

Remember this?

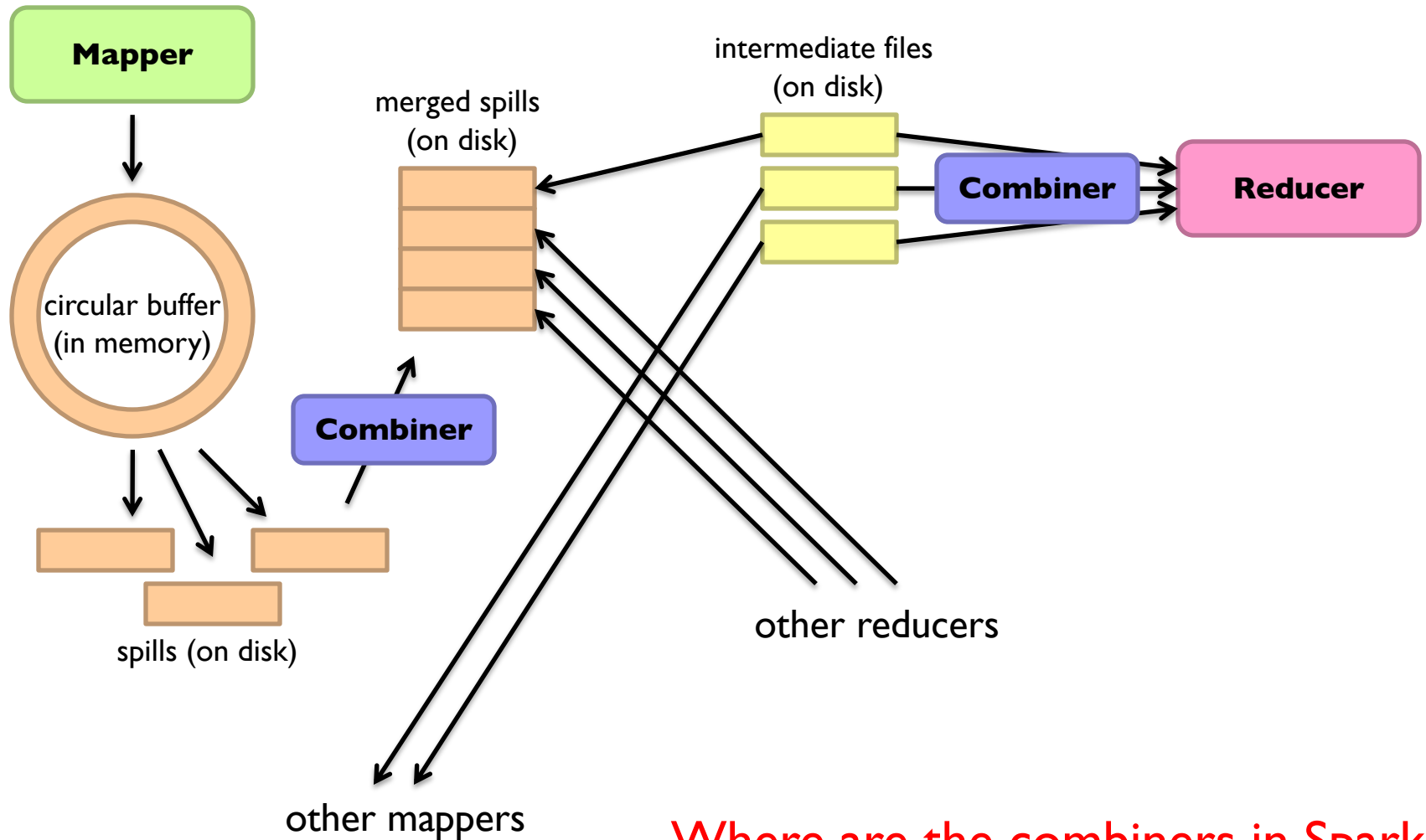

Where are the combiners in Spark?

Reduce-like Operations

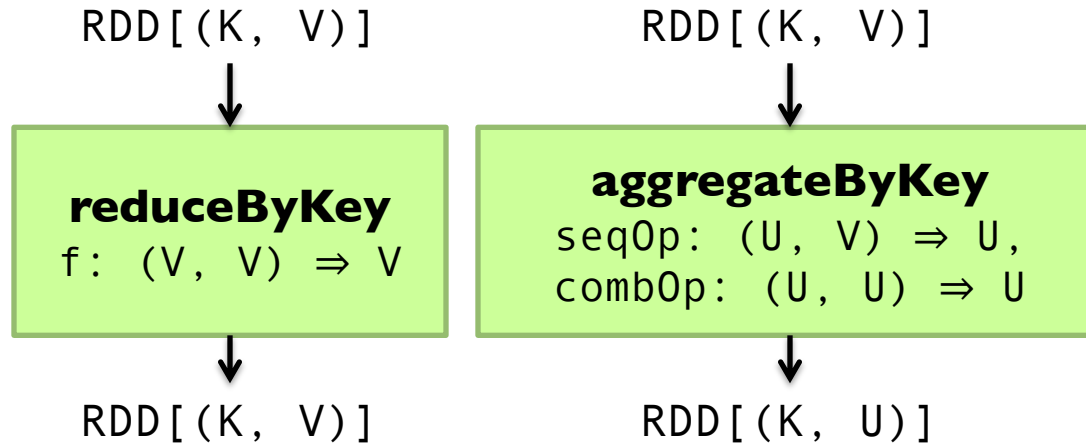

What happened to combiners?

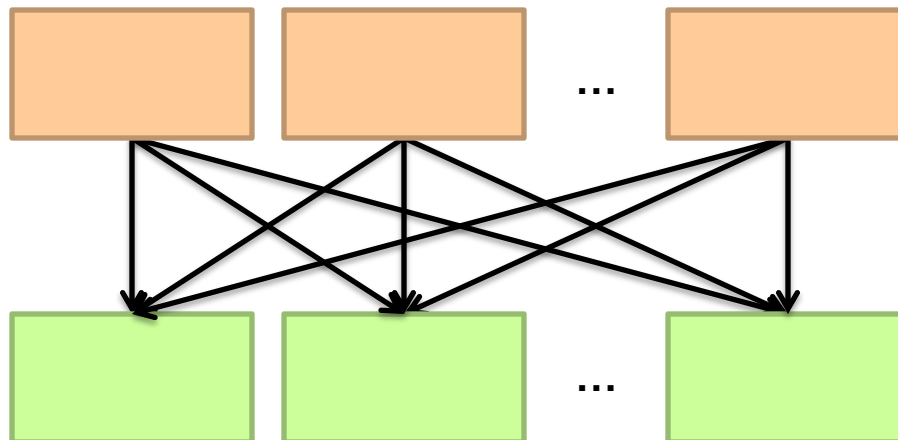

Spark #wins

Richer operators

RDD abstraction supports
optimizations (pipelining, caching, etc.)

Scala, Java, Python, R, bindings

Spark #wins

Quick Start Using Scala (Scala) Import Notebook

```
> // Take a look at the file system
display(dbutils.fs.ls("/databricks-datasets/samples/docs/"))
```

| path | name | size |
|--------------------------------------------------|-----------|------|
| dbfs:/databricks-datasets/samples/docs/README.md | README.md | 3137 |

```
> // Setup the textFile RDD to read the README.md file
// Note this is lazy
val textFile = sc.textFile("/databricks-datasets/samples/docs/README.md")

textFile: org.apache.spark.rdd.RDD[String] = /databricks-datasets/samples/docs/README.md MapPartitionsRDD[1873222] at textFile at <console>:34
```

RDDs have **actions**, which return values, and **transformations**, which return pointers to new RDDs.

```
> // When performing an action (like a count) this is when the textFile is read and aggregate calculated
// Click on [View] to see the stages and executors
textFile.count()

res2: Long = 65
```

Scala Count (Jobs)

Jobs Stages Storage Environment Executors SQL JDBC/ODBC Server

Spark #lose

Java serialization (w/ Kryo optimizations)

Scala: poor support for primitives



Algorithm design, redux



Two superpowers:

Associativity
Commutativity
(sorting)

What follows... very basic category theory...

The Power of Associativity

You can put parentheses where ever you want!

$$\left(v_1 \oplus v_2 \oplus v_3 \right) \oplus \left(v_4 \oplus v_5 \oplus v_6 \oplus v_7 \right) \oplus \left(v_8 \oplus v_9 \right)$$

$$\left(v_1 \oplus v_2 \right) \oplus \left(v_3 \oplus v_4 \oplus v_5 \right) \oplus \left(v_6 \oplus v_7 \oplus v_8 \oplus v_9 \right)$$

$$\left(v_1 \oplus v_2 \oplus \left(v_3 \oplus v_4 \oplus v_5 \right) \right) \oplus \left(v_6 \oplus v_7 \oplus v_8 \oplus v_9 \right)$$

The Power of Commutativity

You can swap order of operands however you want!

$$\left(v_1 \oplus v_2 \oplus v_3 \right) \oplus \left(v_4 \oplus v_5 \oplus v_6 \oplus v_7 \right) \oplus \left(v_8 \oplus v_9 \right)$$

$$\left(v_4 \oplus v_5 \oplus v_6 \oplus v_7 \right) \oplus \left(v_1 \oplus v_2 \oplus v_3 \right) \oplus \left(v_8 \oplus v_9 \right)$$

$$\left(v_8 \oplus v_9 \right) \oplus \left(v_4 \oplus v_5 \oplus v_6 \oplus v_7 \right) \oplus \left(v_1 \oplus v_2 \oplus v_3 \right)$$

Implications for distributed processing?

You don't know when the tasks begin

You don't know when the tasks end

You don't know when the tasks interrupt each other

You don't know when intermediate data arrive

...

It's okay!

Word Count: Baseline

```
class Mapper {
  def map(key: Long, value: String) = {
    for (word <- tokenize(value)) {
      emit(word, 1)
    }
  }
}

class Reducer {
  def reduce(key: String, values: Iterable[Int]) = {
    for (value <- values) {
      sum += value
    }
    emit(key, sum)
  }
}
```

Fancy Labels for Simple Concepts...

Semigroup = (M, \oplus)

$\oplus : M \times M \rightarrow M$, s.t., $\forall m_1, m_2, m_3 \in M$

$$(m_1 \oplus m_2) \oplus m_3 = m_1 \oplus (m_2 \oplus m_3)$$

Monoid = Semigroup + identity

ε s.t., $\varepsilon \oplus m = m \oplus \varepsilon = m$, $\forall m \in M$

Commutative Monoid = Monoid + commutativity

$\forall m_1, m_2 \in M$, $m_1 \oplus m_2 = m_2 \oplus m_1$

A few examples?
(hint, previous slide!)

Back to these...

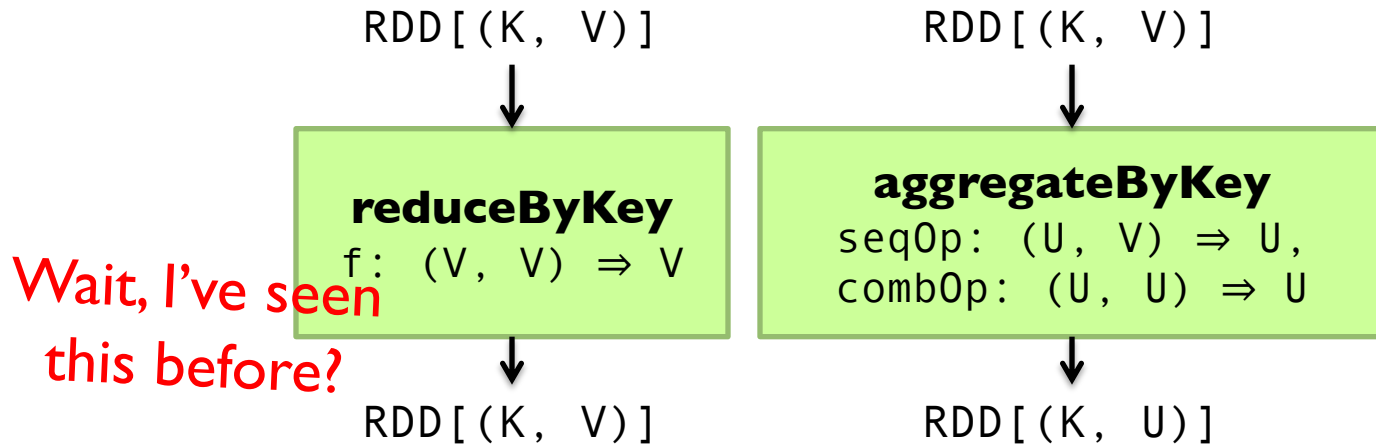

Computing the Mean: Version I

```
class Mapper {
  def map(key: String, value: Int) = {
    emit(key, value)
  }
}

class Reducer {
  def reduce(key: String, values: Iterable[Int]) {
    for (value <- values) {
      sum += value
      cnt += 1
    }
    emit(key, sum/cnt)
  }
}
```

Computing the Mean: Version 3

```
class Mapper {
  def map(key: String, value: Int) =
    context.write(key, (value, 1))
}
class Combiner {
  def reduce(key: String, values: Iterable[Pair]) = {
    for ((s, c) <- values) {
      sum += s
      cnt += c
    }
    emit(key, (sum, cnt))
  }
}
class Reducer {
  def reduce(key: String, values: Iterable[Pair]) = {
    for ((s, c) <- values) {
      sum += s
      cnt += c
    }
    emit(key, sum/cnt)
  }
}
```

*Wait, I've seen
this before!*

RDD[(K, V)]



reduceByKey
f: (V, V) => V



RDD[(K, V)]

Co-occurrence Matrix: Stripes

```
class Mapper {  
  def map(key: Long, value: String) = {  
    for (u <- tokenize(value)) {  
      val map = new Map()  
      for (v <- neighbors(u)) {  
        map(v) += 1  
      }  
      emit(u, map)  
    }  
  }  
}
```

Wait, I've seen this before?

```
class Reducer {  
  def reduce(key: String, values: Iterable[Map]) = {  
    val map = new Map()  
    for (value <- values) {  
      map += value  
    }  
    emit(key, map)  
  }  
}
```

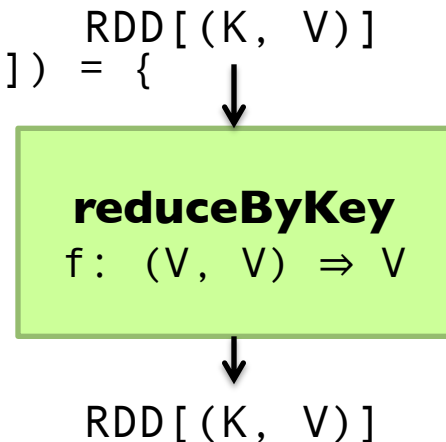

Computing the Mean: Version 2

```
class Mapper {
  def map(key: String, value: Int) =
    context.write(key, value)
}
class Combiner {
  def reduce(key: String, values: Iterable[Int]) = {
    for (value <- values) {
      sum += value
      cnt += 1
    }
    emit(key, (sum, cnt))
  }
}
class Reducer {
  def reduce(key: String, values: Iterable[Pair]) = {
    for ((s, c) <- values) {
      sum += s
      cnt += c
    }
    emit(key, sum/cnt)
  }
}
```

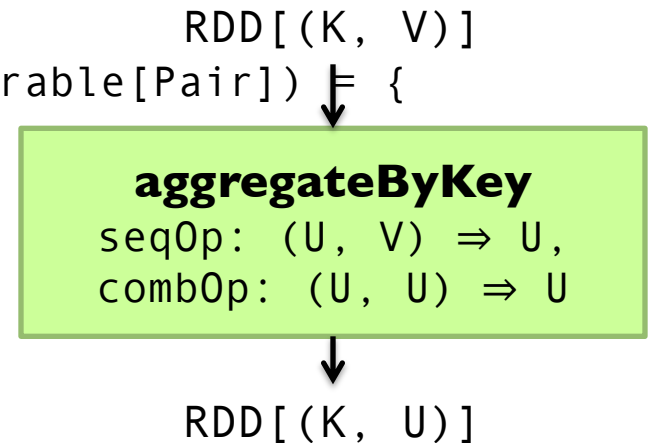

Synchronization: Pairs vs. Stripes

Approach 1: turn synchronization into an ordering problem

Sort keys into correct order of computation

Partition key space so each reducer receives appropriate set of partial results

Hold state in reducer across multiple key-value pairs to perform computation

Illustrated by the “pairs” approach

Approach 2: data structures that bring partial results together

Each reducer receives all the data it needs to complete the computation

Illustrated by the “stripes” approach

Commutative monoids!

Because you can't avoid this...

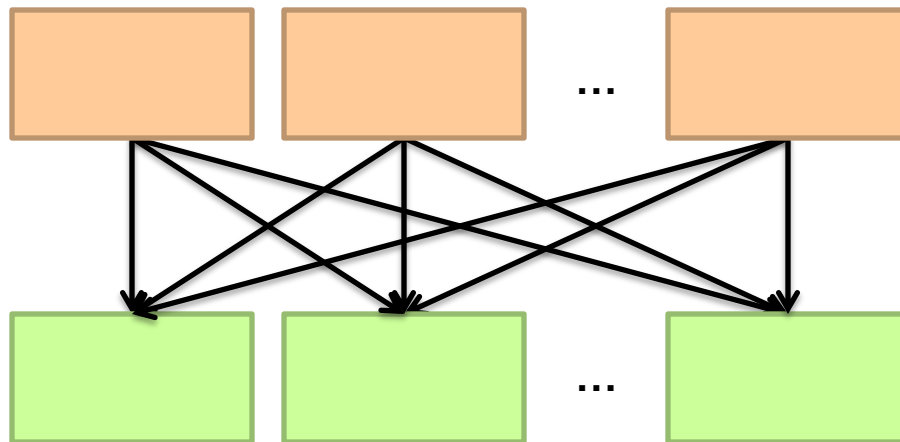

But commutative monoids help

Synchronization: Pairs vs. Stripes

Approach 1: turn synchronization into an ordering problem

Sort keys into correct order of computation

Partition key space so each reducer receives appropriate set of partial results

Hold state in reducer across multiple key-value pairs to perform computation

Illustrated by the “pairs” approach

What about this?

Approach 2: data structures that bring partial results together

Each reducer receives all the data it needs to complete the computation

Illustrated by the “stripes” approach

Commutative monoids!

$f(B|A)$: “Pairs”

$(a, *) \rightarrow 32$

$(a, b_1) \rightarrow 3$

$(a, b_2) \rightarrow 12$

$(a, b_3) \rightarrow 7$

$(a, b_4) \rightarrow 1$

...

Reducer holds this value in memory



$(a, b_1) \rightarrow 3 / 32$

$(a, b_2) \rightarrow 12 / 32$

$(a, b_3) \rightarrow 7 / 32$

$(a, b_4) \rightarrow 1 / 32$

...

For this to work:

Emit extra $(a, *)$ for every b_n in mapper

Make sure all a 's get sent to same reducer (use partitioner)

Make sure $(a, *)$ comes first (define sort order)

Hold state in reducer across different key-value pairs



Two superpowers:

Associativity
Commutativity
(sorting)

When you can't “monoidify”

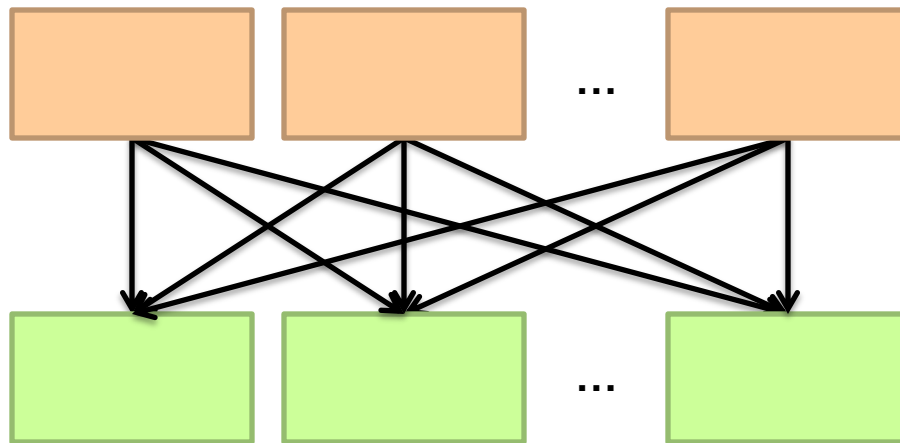

Sequence your computations by sorting

An Apt Quote

All problems in computer science can be solved by another level of indirection... Except for the problem of too many layers of indirection.

- David Wheeler

An aerial photograph of a large industrial datacenter facility during sunset. The sun is a bright orange orb in the upper left corner, casting a warm glow over the scene. The facility consists of several large, white, rectangular buildings with flat roofs, arranged in a grid-like pattern. In the foreground, there are several large, white, cylindrical storage tanks or containers. The surrounding area is a mix of green fields and brown, tilled soil. The sky is a gradient of orange and yellow, transitioning into a darker blue at the horizon.

The datacenter *is* the computer!

What's the instruction set?
What are the abstractions?

Algorithm design in a nutshell...



Exploit associativity and commutativity
via commutative monoids (if you can)

Exploit framework-based sorting to
sequence computations (if you can't)



Source: Wikipedia (Japanese rock garden)